

1	2	3	4	5	6	7	8	9
Customer Part No.	11.08.03.00136							
Customer Name	DBS3500-PV-MPPT-XT60-M连接线(自研)							

RoHS
COMPLIANT

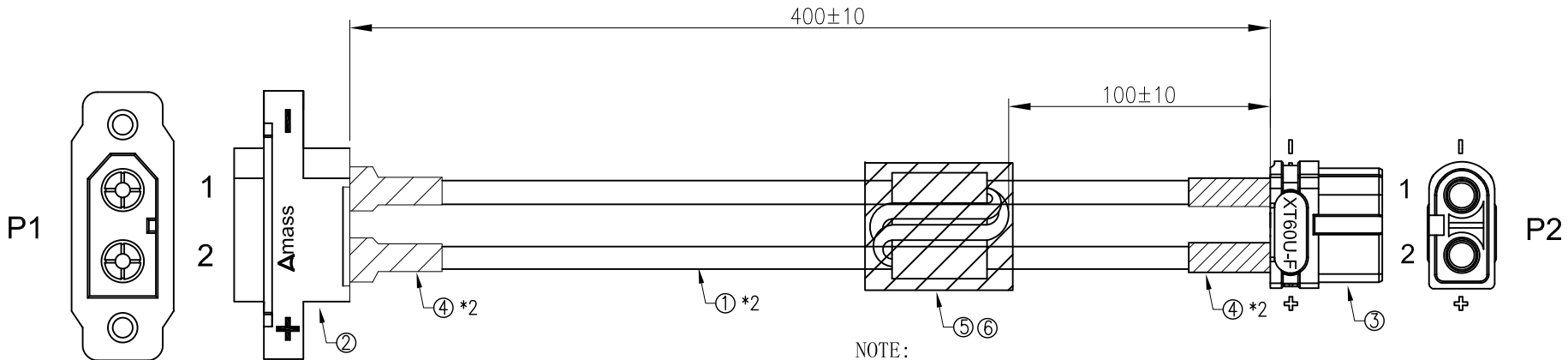

NOTE:
电线绕磁环内2外1,
外加热缩套管固定

⑥	Core	磁环: NJ162803 (昊华科)	1	pcs
⑤	Tube	黑色热缩套管	1	pcs
④	Tube	黑色热缩套管 L=15mm	4	pcs
③	Plug	XT60U-F 黄色	1	pcs
②	Plug	XT60E-M 黄色	1	pcs
①	Wire	UL3135 12AWG 硅胶线 白/黑	2	pcs
NO.	Material	Description	Q'TY	Unit

WIRE LIST

P1	Color	P2	Remark
1	白色	1	
2	黑色	2	

注意事项:
1. 100%短路, 断路, 错位测试.

A4				TITLE: XT60E-M TO XT60U-F L=400mm		DRAWN: 车忠浩 2024.08.07		KONNRA 东莞市康瑞电子有限公司	
						CHECKED:		DongGuan Konnra Electronics Co.,Ltd.	
						APPROVED:		PART NO.:XSZ11101136	
MARK	REVISION DESCRIPTION	SIGNATURE	DATE	UNIT:mm	SCALE:N/A	SHEET:1/1	PROJECTION	REV.:A1	DRAWING NO.:XSZ11101136S