

RoHS
COMPLIANT

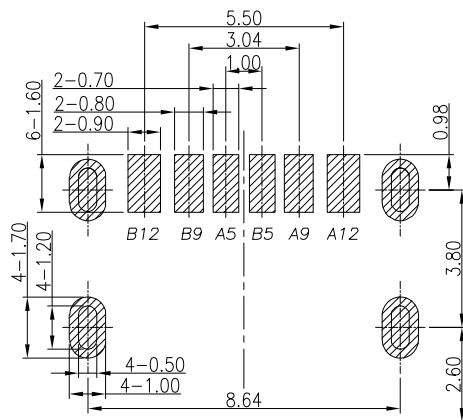
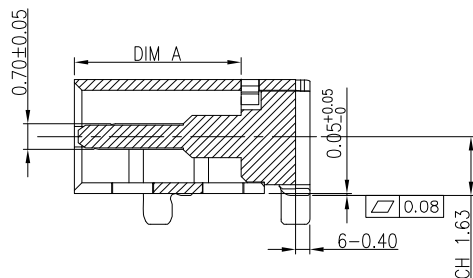
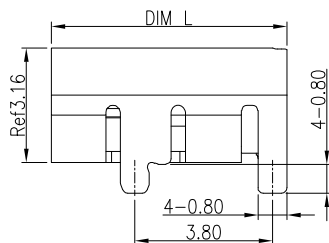
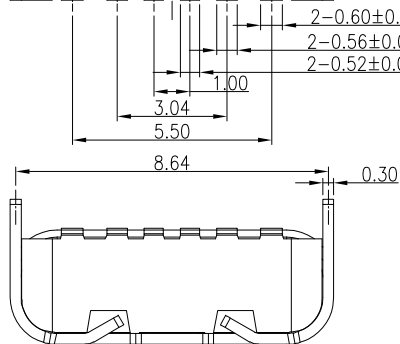
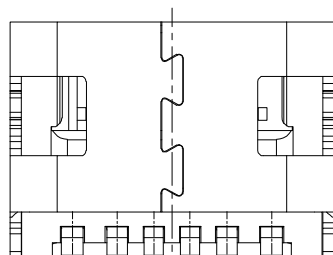
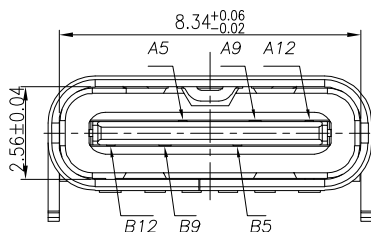
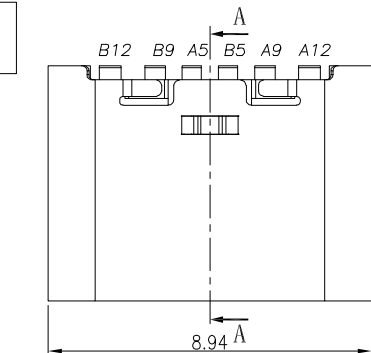

Recommended P.C.B. Layout
Total tolerance: ±0.05

NOTE:

1.MATERIAL SPECIFICATION:

- 1.HOUSING: HIGH TEMPERATURE RESISTANT PLASTIC, UL94 V-0.
- 2.CONTACTS: COPPER ALLOY

2.PLATING SPECIFICATION:

2-1.CONTACTS:

- Ni 50u" MIN. UNDER PLATED OVER ALL.
- Au PLATED ON THE FUNCTIONAL AREA OF CONTACT.
- (GOLD PLATING THICKNESS FOLLOW THE P/N)
- GOLD FLASH PLATING ON SOLDER AREA

2-2.FRONT SHELL:

- Ni 30u" MIN. UNDER PLATED OVER ALL.

3.MECHANICAL PERFORMANCE,

- 3-1.INSERTION FORCE: 0.5~2.0kgf.
- 3-2.REMOVAL FORCE: 0.8kgf~2.0kgf.
- 3-3.DURABILITY: 3000 CYCLES.

4.ELECTRICAL PERFORMANCE,

- 4-1. CURRENT RATING: 5.0A
VOLTAGE RATING: 20V
- 4-2.INSULATION RESISTANCE: 100MΩ MIN
- 4-3.DIELECTRIC WITHSTAND VOLTAGE, AC 100V FOR 1 MINUTE.
- 4-4.LOW CONTACT RESISTANCE: INITIAL 40MΩ /AFTER 50MΩ

5. ENVIRONMENTAL PERFORMANCE:

- OPERATING TEMPERATURE: -30°C~+80°C.

6.IR REFLOW:

- THE PEAK TEMPERATURE ON THE BOARD SHALL BE MAINTAINED FOR 10 SECONDS AT 260°C.

Code	DIM L	DIM A
0	6.80	4.90

USB TYPE-C PIN ASSIGNMENTS

PIN NUMBER	SIGNAL NAME
A5	CC1
A9	VBUS
A12	GND
B12	GND
B9	VBUS
B5	CC2

TOLERANCE
X.X ±0.35
X.XX ±0.25
X.XXX ±0.15
Angle ±2°

TITLE:
TYPE-C 6P 母座底板
上四脚插 L=6.80
CH1.63

DRAWN: *ZS* 2021.10.12

CHECKED:

APPROVED:

KONNRA 东莞市康瑞电子有限公司
DongGuan Konnra Electronics Co.,Ltd.

PART NO.: U04S0003R



MARK

REVISION DESCRIPTION

SIGNATURE

DATE

UNIT:mm SCALE:N/A

SHEET: 1/1

PROJECTION

REV.: A1

DRAWING NO.: U04S0003R-S