

**RoHS**  
COMPLIANT

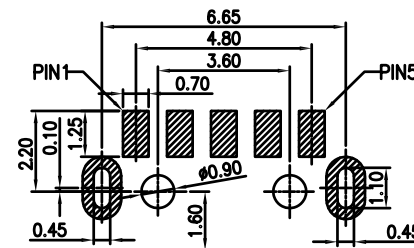

Recommended P.C.B. Layout  
General tolerance: ±0.05mm

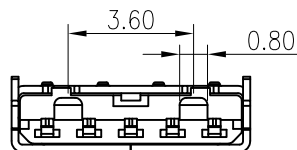
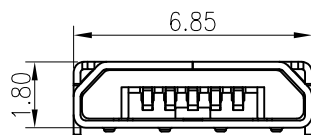
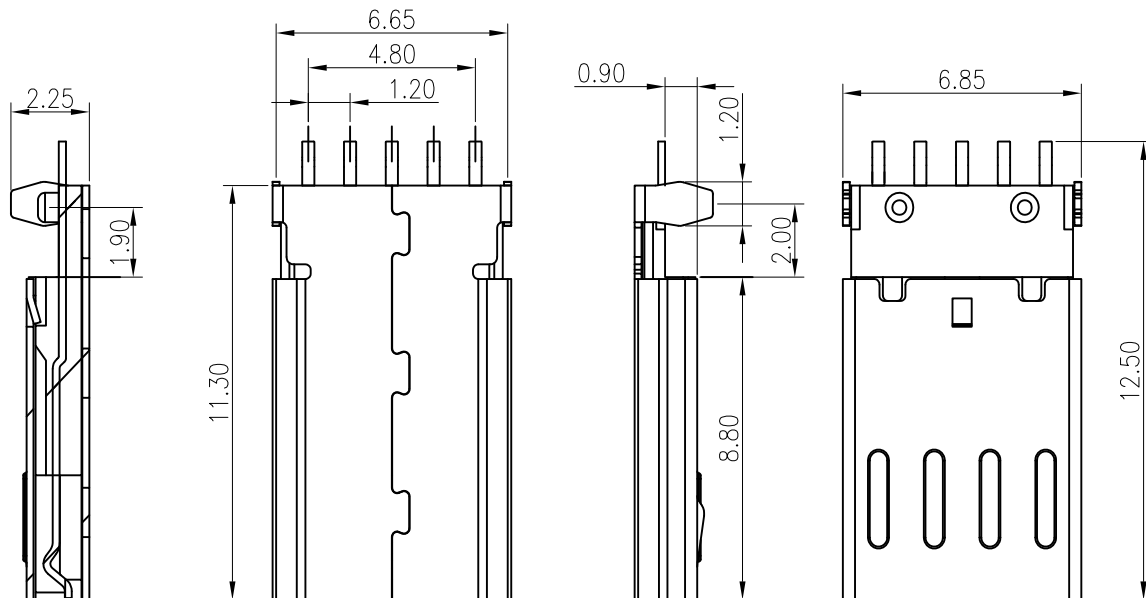

NOTES:

- MATERIALS
  - INSULATOR: LCP BLACK,UL94V-0
  - SHELL: SUS WITH NI PLATED.
  - CONTACT: BRASS WITH GOLD FLASH ON CONTACT AREA, AND TIN PLATED ON SOLDER TAIL.
  - DURABILITY: 5000 CYCLES.
- ELECTRICAL
  - INSULATION RESISTANCE: 100 MEGOHMS MINIMUM.
  - DIELECTRIC WITHSTANDING VOLTAGE: 500V DC R.M.S.
  - VOLTAGE RATING: 30V.
  - CURRENT RATING: 2 AMP.(PIN1,5),1 AMP.(PIN2,3,4)
  - CONTACT RESISTANCE: 50 MILLIOHMS MAXIMUM.
- ENVIRONMENTAL
  - TEMPERATURE RANGE: -40°C TO +85°C.

Pin Assignments

Contact No.	Signal Name
1	VBUS
2	D-
3	D+
4	ID
5	GND
SHELL	Shield

F					TOLERANCE	TITLE:	DRAWN: <i>Arwin 2021.07.16</i>	KONNRA 东莞市康瑞电子有限公司 DongGuan Konnra Electronics Co.,Ltd.			
					X.X ±0.30	Micro USB 5P Male	CHECKED:				
		更改端子形状	ZSZ	2022.9.23	X.XX ±0.20	SMT Type 沉板式	APPROVED:	PART NO.:U01P0002B			
	MARK	REVISION DESCRIPTION	SIGNATURE	DATE	X.XXX ±0.10	带柱	UNIT:mm	SCALE:N/A	SHEET:1/1	PROJECTION	REV.:A2
	1	2	3	4	5	6	7	8	9		