

RoHS  
COMPLIANT

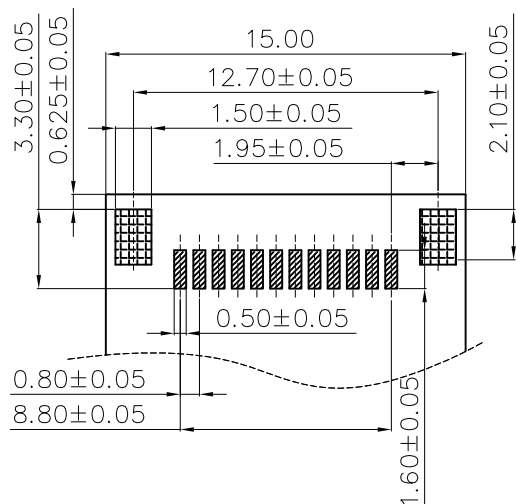
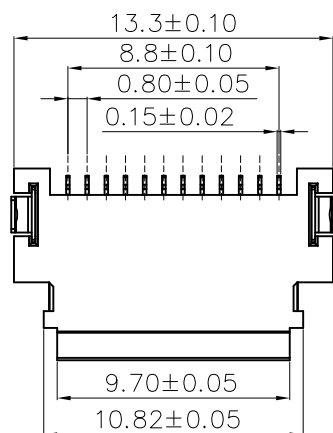

Recommended P.C.B. Layout

1. MATERIAL:  
HOUSING: HEIGHT TERMOPLASTIC, UL94V-0, COLOR: WHITE  
CONTACT: PHOSPHOR BRONZE, T=0.15mm  
PEG: STAINLESS STEEL, T=0.15mm
2. FINISH:  
-CONTACT AREA: GOLD FLASH OVER Ni 30u"Min  
-SMD AREA: GOLD FLASH  
PEG: M-Tin100u" Min.
3. OPERATING TEMPERATURE: -40~105°C
4. OPERATING VOLTAGE: 100V AC/DC.
5. CURRENT RATING: 2.0AMPS.
6. DIELECTRIC WITHSTANDING VOLTAGE: 250V AC/MINUTE.
7. INSULATION RESISTANCE: 500mΩ MIN.
8. CONTACT RESISTANCE: 20mΩ MAX.

PARTS LIST:

NO.	DESCRIPTION	Q' TY	MATERIAL	FINISH
3	PEG	2	SUS	Tin-Plated
2	CONTACT	12	PHOSPHOR BRONZE	Au-Plated
1	HOUSING	1	LCP	WHITE

A03  
A02  
A01

MARK

TOLERANCE  
X.X ±0.30  
X.XX ±0.20  
X.XXX ±0.10  
Angle ±2°

TITLE:  
3SETS 12.1 PLUG  
CONN.

UNIT:mm SCALE:1:1

DRAWN: LCC 2024.06.13

CHECKED:

APPROVED:

SHEET:1/2

PROJECTION

KONNRA 东莞市康瑞电子有限公司  
DongGuan Konnra Electronics Co.,Ltd.

PART NO.: QZ000372

REV.: A01 DRAWING NO.: QZ000372-S

1 2 3 4 5 6 7 8 9

A  
B  
C  
D  
E  
F

A  
B  
C  
D  
E  
F

1 2 3 4 5 6 7 8 9