

**RoHS**  
COMPLIANT

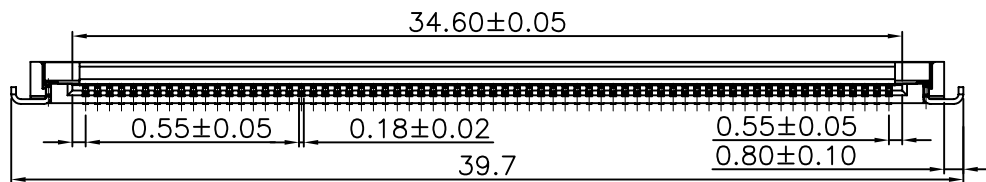

NOTES:

- MATERIAL:  
HOUSING: THERMOPLASTIC (UL94V-0), NATURE  
ACTUATOR: THERMOPLASTIC (UL94V-0), BLACK  
TERMINAL: PHOSPHOR BRONZE, UNDER PLATED MIN 50 $\mu$ "  
NICKEL OVERALL, GOLDDR MIN 3 $\mu$ " FOR CONTACT  
AREA, GOLD MIN 1 $\mu$ " FOR SOLDER AREA  
FITTING NAIL: BRASS, UNDER PLATED MIN 50 $\mu$ " NICKEL  
AND MATTE TIN MIN 100 $\mu$ " ALLOVER

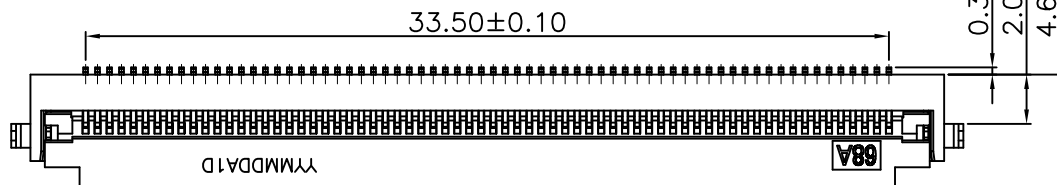
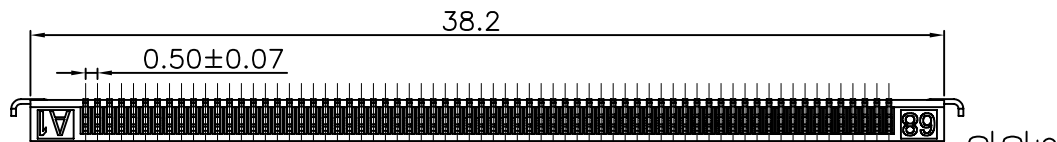
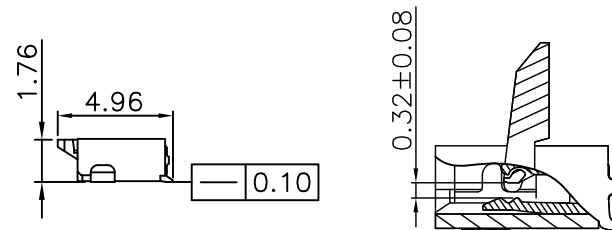

OPEN POSITION  
SCALE 2:1

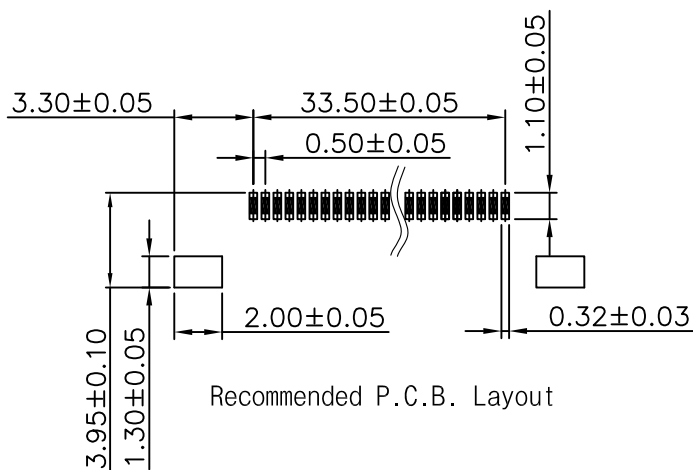

Recommended P.C.B. Layout

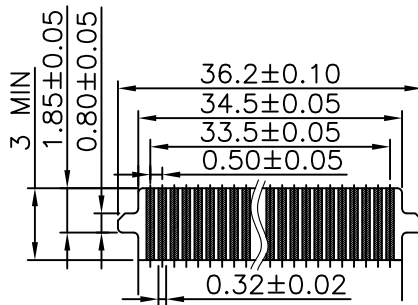

Recommended FFC Dim

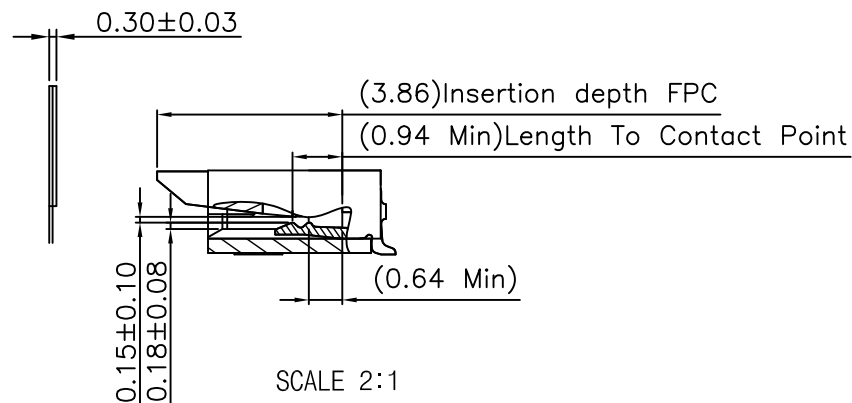

SCALE 2:1

A03

A02

A01

MARK

TOLERANCE

X.X ±0.30

X.XX ±0.20

X.XXX ±0.10

Angle ±2°

TITLE:

FPC 68.4 CONN.

UNIT:mm

SCALE:1:1

DRAWN:

LCC 2024.06.13

CHECKED:

APPROVED:

SHEET:1/2

PROJECTION

**KONNRA** 东莞市康瑞电子有限公司

DongGuan Konnra Electronics Co.,Ltd.

PART NO.: A050096813G0305RL

REV.: A01 DRAWING NO.: A0500905-L-S