

**RoHS**  
COMPLIANT

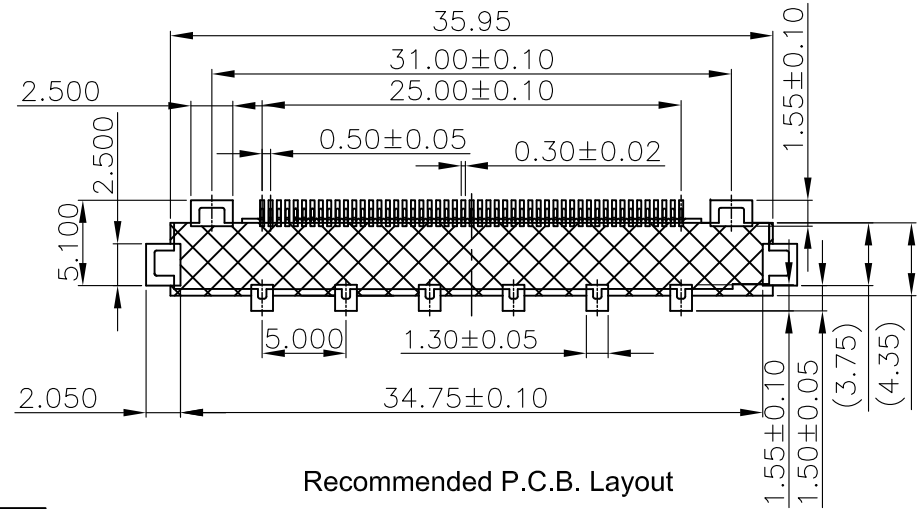

Recommended P.C.B. Layout

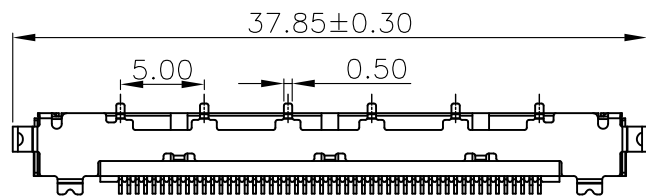
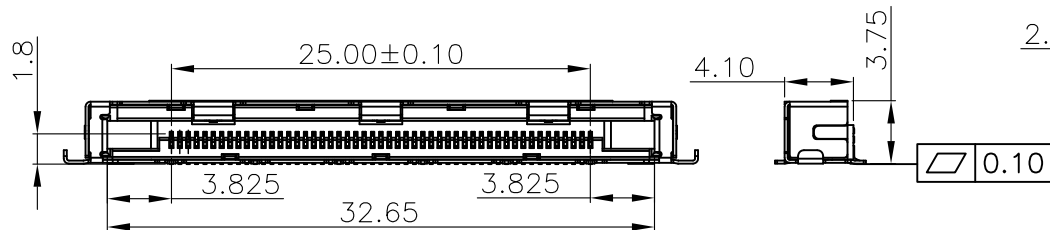
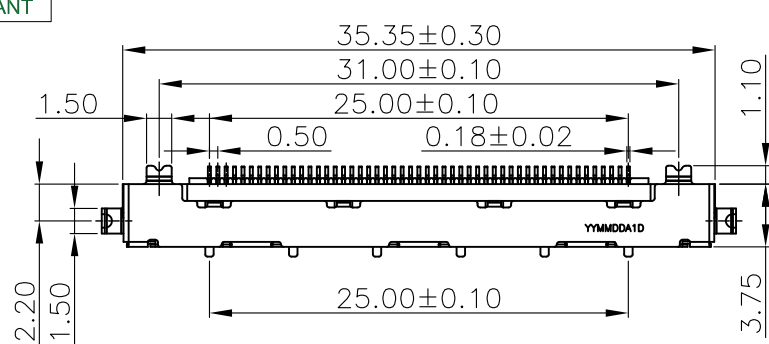
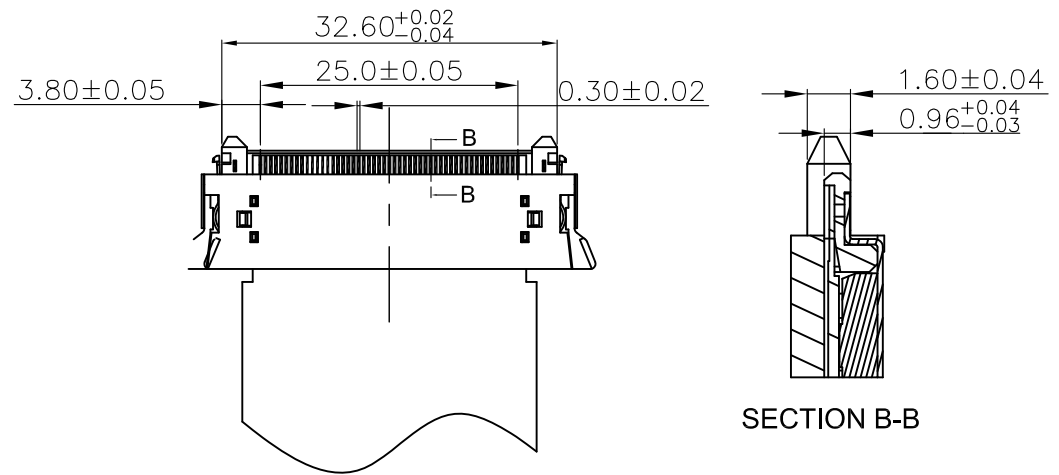

Recommended FPC Dim

SECTION B-B

**NOTES:**

**1.MATERIAL:**

- 1.1 HOUSING: THERMOPLASTIC, HIGH TEMP.UL94V-0; COLOR:BLACK
- 1.2 CONTACT: COPPER ALLOY,T=0.18mm.
- 1.3 SHELL:SUS 304 1/2,T=0.18mm.

**2.FINISH:**

- 2.1 CONTACT AREA:AU3u" MIN OVER NI 30u"Min,SMD AREA:GOLD FLASH.
- 2.2 SHELL SMD AREA: GOLD FLASH.

AQ3

AQ2

AQ1

MARK

TOLERANCE

- X.X ±0.30
- X.XX ±0.20
- X.XXX ±0.10
- Angle ±2°

TITLE:

LVDS 51P REC  
CONN.

DRAWN: LCC 2024.06.13

CHECKED:

APPROVED:

**KONNRA** 东莞市康瑞电子有限公司  
DongGuan Konnra Electronics Co.,Ltd.

PART NO.: C0501RS15114G0301RB

UNIT:mm SCALE:1:1

SHEET:1/2 PROJECTION

REV.:A01 DRAWING NO.:0501WFRS101-B-S