

RoHS
COMPLIANT

Step 1: Place Housing into PE bag and seal PE bag. Label.
将 Housing放入PE袋内, 并将PE袋封好, 贴上标签.

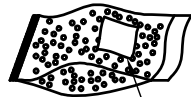
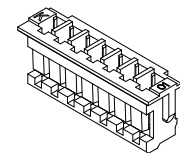

Label

Step 2: Put PE bag packed products in cartons,
Packing detail see the table right
将装好产品的PE袋放入纸箱内, 详细包装见右表

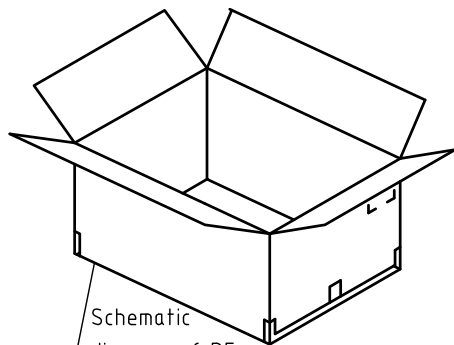

Schematic diagram of PE bag placement

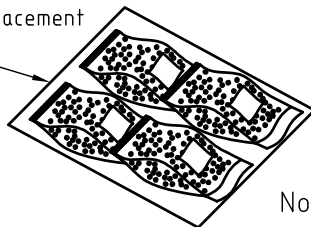

Step 3: Put PE bag packed products in cartons,
Packing detail see the table right
将装好产品的PE袋放入纸箱内, 详细包装见右表

Adhesive Tape

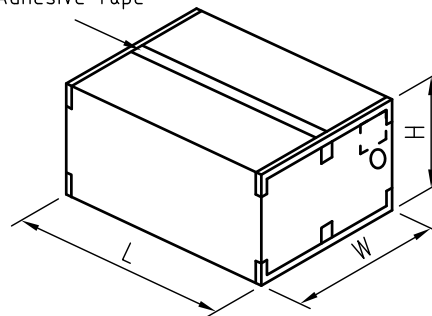

Circuits	PCS/Bag
2	1000
3	1000
4	1000
5	1000
6	1000
7	1000
8	1000
9	1000
10	1000
11	1000
12	1000
13	1000
14	1000
15	1000
16	1000

Note注解:

1. There shall be no dirt such as deformation phenomenon, Mantissa box fillers must be used
每箱不可有脏污, 变形现象, 尾数箱必须用填充物
2. Confirm whether the inner and outer labels are missing and the content must be consistent with the actual product
确认内外标签有无漏失, 内容与实物必须一致
3. Packing quantity per carton depends on order and delivery quantity
每箱包装数量依订单及交货数量而定

	SPEC.	Remark
Carton 1	L460mm×W460mm×H510mm	Use the appropriate carton size according to the actual order quantity 根据实际订单数量使用合适的纸箱尺寸
Carton 2	L500mm×W500mm×H305mm	
Carton 3	L580mm×W580mm×H320mm	



MARK

TOLERANCE
X.X ±0.30
X.XX ±0.20
X.XXX ±0.10
Angle ±2°

TITLE:
ZH1.50 HOUSING
Packing

DRAWN: *Arwin 2020.03.05*

CHECKED:

APPROVED:

KONNRA 东莞市康瑞电子有限公司
DongGuan Konnra Electronics Co.,Ltd.

PART NO.: H15010****01A

UNIT:mm SCALE:N/A SHEET:1/1 PROJECTION REV.:A1 DRAWING NO.:1501H01-A-P

1 2 3 4 5 6 7 8 9

RoHS
COMPLIANT

Lable



线夹朝上 (Clamp facing up)



Adhesive Tape

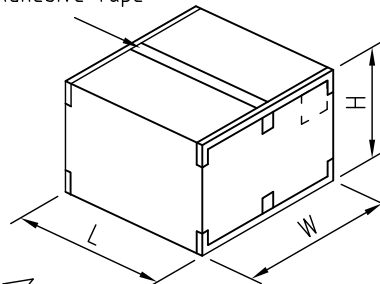

Package way

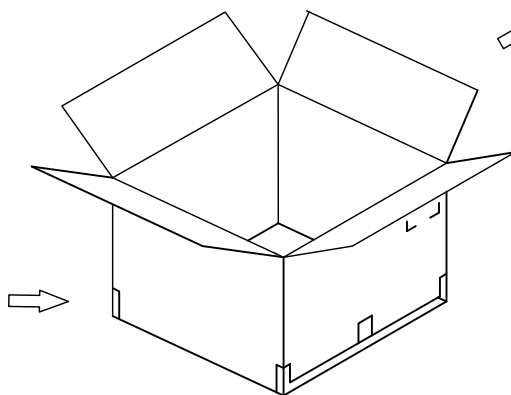
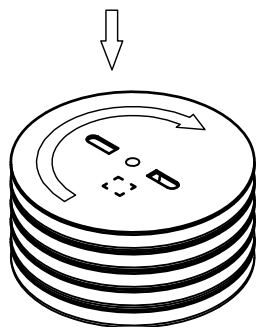

Note注解:

1. There shall be no dirt such as deformation phenomenon, Mantissa box fillers must be used
每箱不可有脏污，变形现象，尾数箱必须用填充物
2. Confirm whether the inner and outer labels are missing and the content must be consistent with the actual product
确认内外标签有无漏失，内容与实物必须一致
3. Quantity(数量): 20K PCS/REEL (20K PCS/盘)
Packing quantity per carton depends on order and delivery quantity
每箱包装数量依订单及交货数量而定

	SPEC.	Remark
Carton 1	L460mm×W460mm×H510mm	Use the appropriate carton size according to the actual order quantity 根据实际订单数量使用合适的纸箱尺寸
Carton 2	L500mm×W500mm×H305mm	
Carton 3	L580mm×W580mm×H320mm	



MARK

1

2

3

4

5

6

7

8

9

TOLERANCE

X.X ±0.30

X.XX ±0.20

X.XXX ±0.10

Angle ±2°

TITLE:
ZH1.50 Terminal
Packing

UNIT:mm

SCALE:N/A

DRAWN: Arwin 2020.03.05

CHECKED:

APPROVED:

SHEET:1/1

PROJECTION

KONNRA 东莞市康瑞电子有限公司
DongGuan Konnra Electronics Co.,Ltd.

PART NO.:T15010P***02A

REV.:A1 DRAWING NO.:1501T02-A-P

RoHS
COMPLIANT

Step 1: Place Housing into PE bag and seal PE bag. Label.
将 Housing放入PE袋内, 并将PE袋封好, 贴上标签.

Step 3: Put PE bag packed products in cartons,
Packing detail see the table right
将装好产品的PE袋放入纸箱内, 详细包装见右表

ZH1.5 DIP 90° / ZH1.5 DIP 180°

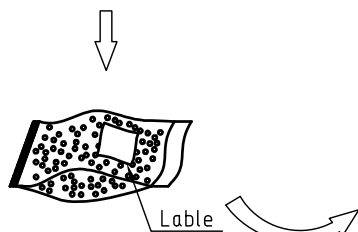
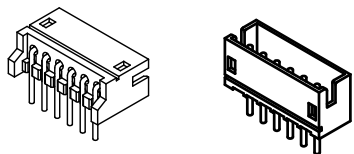

Step 2: Put PE bag packed products in cartons,
Packing detail see the table right
将装好产品的PE袋放入纸箱内, 详细包装见右表

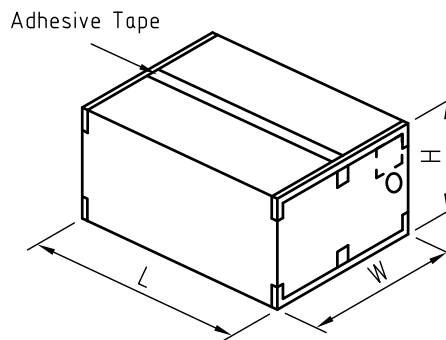
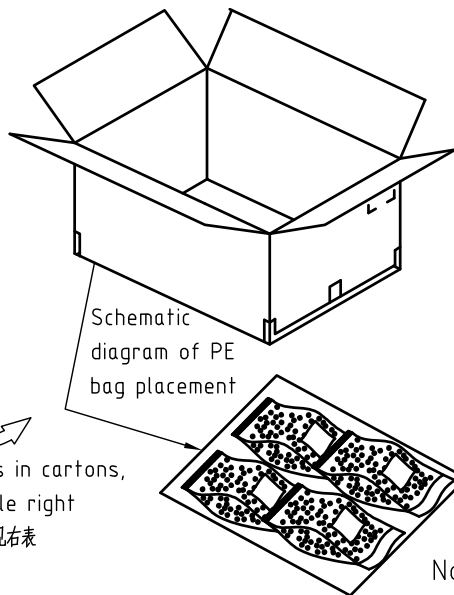

Circuits	PCS/Bag
2	1000
3	1000
4	1000
5	1000
6	1000
7	1000
8	1000
9	1000
10	1000
11	1000
12	1000
13	1000
14	1000
15	1000
16	1000

Note注解:

- There shall be no dirt such as deformation phenomenon, Mantissa box fillers must be used
每箱不可有脏污, 变形现象, 尾数箱必须用填充物
- Confirm whether the inner and outer labels are missing and the content must be consistent with the actual product
确认内外标签有无漏失, 内容与实物必须一致
- Packing quantity per carton depends on order and delivery quantity
每箱包装数量依订单及交货数量而定

	SPEC.	Remark
Carton 1	L460mm×W460mm×H510mm	Use the appropriate carton size according to the actual order quantity 根据实际订单数量使用合适的纸箱尺寸
Carton 2	L500mm×W500mm×H305mm	
Carton 3	L580mm×W580mm×H320mm	

F					TOLERANCE	TITLE:	DRAWN: <i>Arwin 2020.03.05</i>	KONNRA 东莞市康瑞电子有限公司 DongGuan Konnra Electronics Co.,Ltd. PART NO.: C1501*****PA		
					X.X ±0.30	ZH1.50 WF Series	CHECKED:			
					X.XX ±0.20	Packing	APPROVED:			
MARK	REVISION DESCRIPTION	SIGNATURE	DATE	Angle ±2°	UNIT:mm	SCALE:N/A	SHEET:1/1	PROJECTION	REV.:A1	DRAWING NO.: 1501W*D10*-A-S

1 2 3 4 5 6 7 8 9

RoHS
COMPLIANT

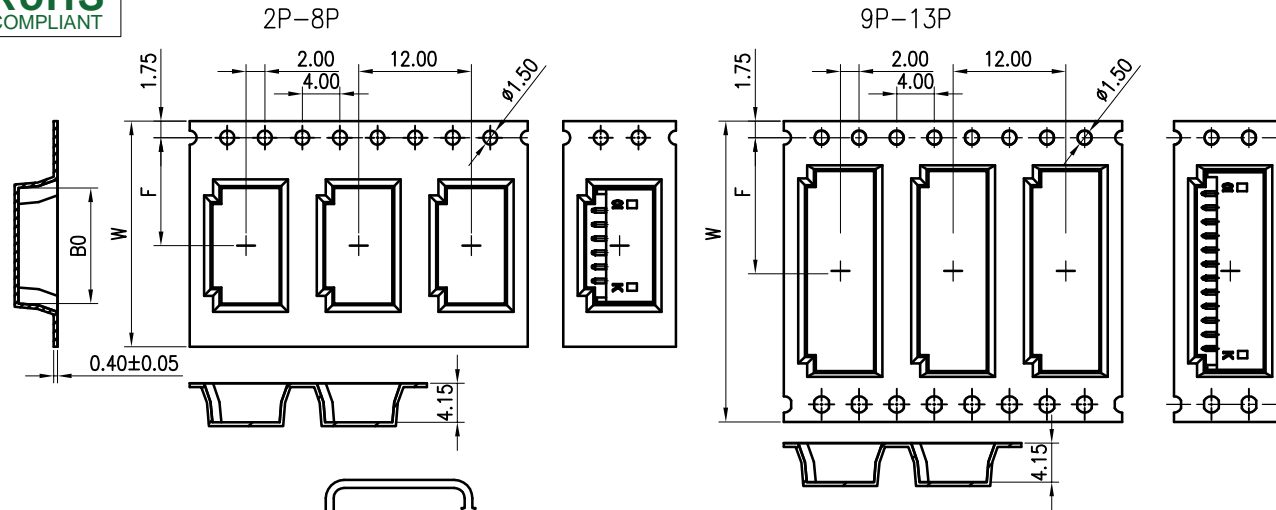

NO.	NAME	SPEC.	Q'TY
①	PRODUCT	ZH1.5 SMT 90°WF系列	1500 PCS/R
②	卷盘/载带	--	1SET
③	透明真空袋	550×500×0.10mm	1PCS/Reel
④	干燥剂	--	1PCS/Reel
⑤	三角纸板	410×80×80mm	2PCS
⑥	纸箱	400×400×420mm	1PCS
⑦	标签	--	2PCS

CKT.	DIMENSIONS			Q'ty/BOX
	W±0.3	B0±0.3	F±0.3	
2-3	16.0	6.30-7.80	7.50	19*1500
4-8	24.0	9.30-15.30	11.50	14*1500
9-12	32.0	16.80-21.30	14.20	11*1500
13	44.0	22.80	20.20	8*1500

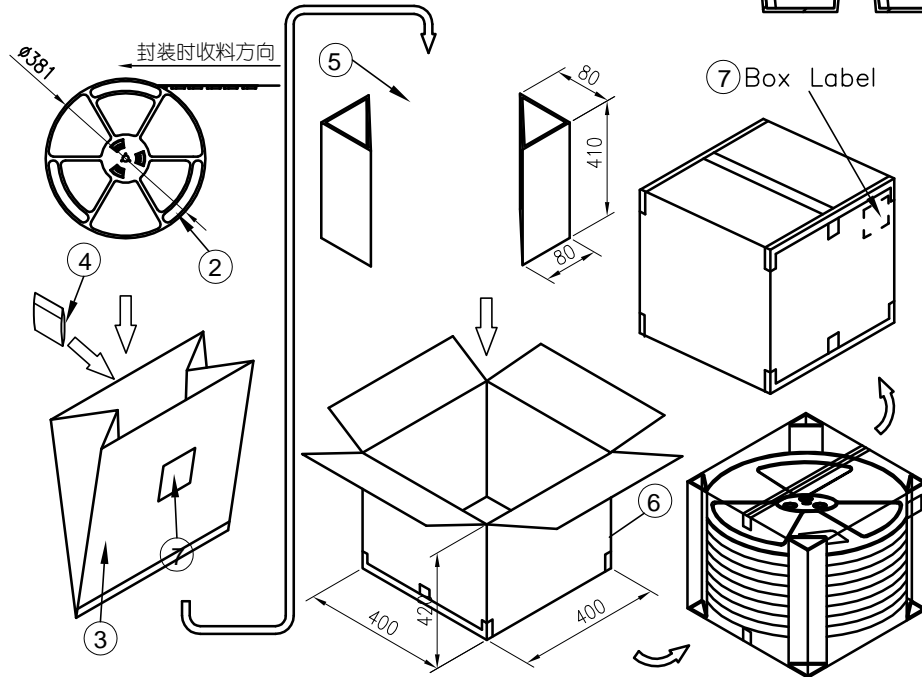

包装方式:

- 产品按要求放入载带卷盘(参考《产品卷带包装对照表》),需测试上带剥离力(剥离角度: 165~180°; 剥离速度: 300±10mm/min):
1.1 W=12~56,剥离力0.1N~1.3N;
1.2 W=72以上,剥离力0.1N~1.5N;
- 产品卷盘包装后,进行抽真空作业(每袋内装入1PCS干燥剂),依要求贴上标签;
- 将三角纸板放入纸箱固定,再将真空包装好的产品放入纸箱内,之后用胶带封箱,并在外箱相应位置贴上标签(若卷盘数量不够整箱,纸箱和三角板高度依实际包装适量修剪或填充).



MARK

1

2

3

4

5

6

7

8

9

TOLERANCE

X.X ±0.30
X.XX ±0.20
X.XXX ±0.10
Angle ±2°

TITLE:
ZH1.5 SMT 90° Wafer
系列包装规范

UNIT: mm SCALE: N/A

DRAWN: Arvin 2021.03.05

CHECKED:

APPROVED:

SHEET: 1/1 PROJECTION

KONNRA 东莞市康瑞电子有限公司
DongGuan Konnra Electronics Co., Ltd.

PART NO.: C1501RS1**11MD101RA

REV.: A1 DRAWING NO.: 1501WRS101-A-P

RoHS
COMPLIANT

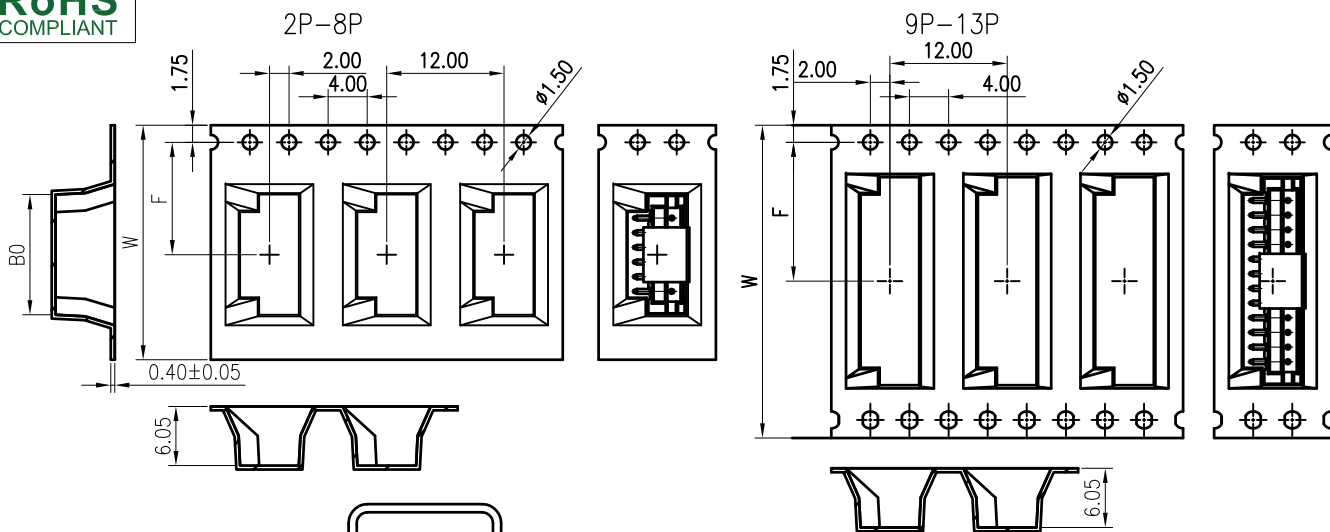

NO.	NAME	SPEC.	Q'TY
①	PRODUCT	ZH1.5 SMT 180°WF系列	1000 PCS/R
②	卷盘/载带	--	1SET
③	透明真空袋	550×500×0.10mm	1PCS/Reel
④	干燥剂	--	1PCS/Reel
⑤	三角纸板	410×80×80mm	2PCS
⑥	纸箱	400×400×420mm	1PCS
⑦	标签	--	2PCS

CKT.	DIMENSIONS			Q'ty/BOX
	W±0.3	B0±0.3	F±0.3	
2-3	16.0	6.30-7.80	7.50	19*1000
4-8	24.0	9.30-15.30	11.50	14*1000
9-12	32.0	16.80-21.30	14.20	11*1000
13	44.0	22.80	20.20	8*1000

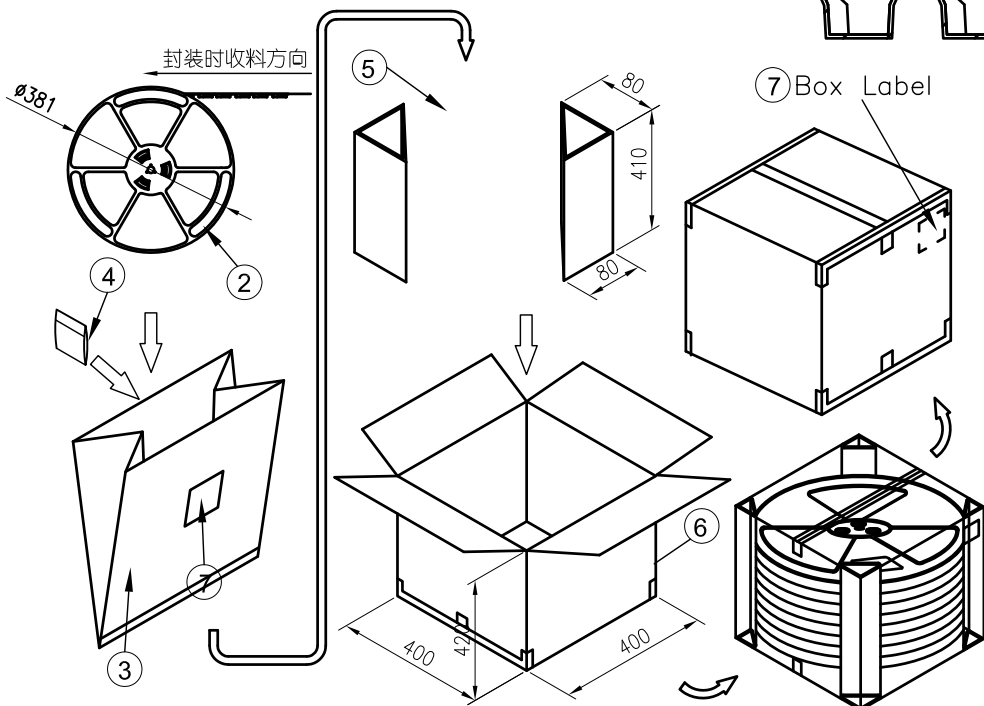

包装方式:

- 产品按要求放入载带卷盘(参考《产品卷带包装对照表》),需测试上带剥离力(剥离角度: 165~180°; 剥离速度: 300±10mm/min);
1.1 W=12~56,剥离力0.1N~1.3N;
1.2 W=72以上,剥离力0.1N~1.5N;
- 产品卷盘包装后,进行抽真空作业(每袋内装入1PCS干燥剂),依要求贴上标签;
- 将三角纸板放入纸箱固定,再将真空包装好的产品放入纸箱内,之后用胶带封箱,并在外箱相应位置贴上标签(若卷盘数量不够整箱,纸箱和三角板高度依实际包装适量修剪或填充).

F	△4				TOLERANCE	TITLE:	DRAWN:	KONNRA 东莞市康瑞电子有限公司 DongGuan Konnra Electronics Co.,Ltd.			
	△3				X.X ±0.30	ZH1.5 SMT 180°	CHECKED:				
	△2	更正纸箱为15寸盘规格	Shen	20220725	X.XX ±0.20	Wafer 系列包装规范	APPROVED:	PART NO.:C1501VS1**11M0101RA			
	MARK	REVISION DESCRIPTION	SIGNATURE	DATE	X.XXX ±0.10	Angle ±2°	UNIT:mm	SCALE:N/A	SHEET:1/1	PROJECTION	REV.:A2
	1	2	3	4	5	6	7	8	9		