

**RoHS**  
COMPLIANT

Step 1: Place Housing into PE bag and seal PE bag. Label.  
将 Housing放入PE袋内, 并将PE袋封好, 贴上标签.

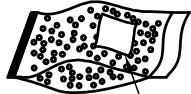
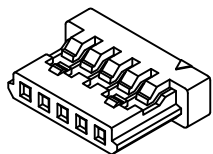

Label

Step 2: Put PE bag packed products in cartons,  
Packing detail see the table right  
将装好产品的PE袋放入纸箱内, 详细包装见右表

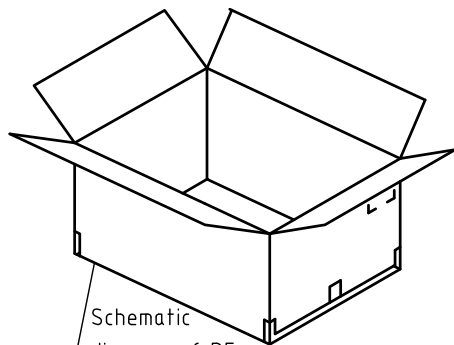

Schematic diagram of PE bag placement

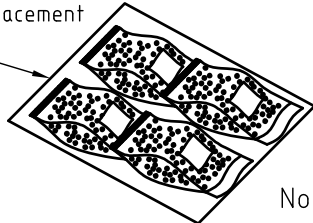

Step 3: Put PE bag packed products in cartons,  
Packing detail see the table right  
将装好产品的PE袋放入纸箱内, 详细包装见右表

Adhesive Tape

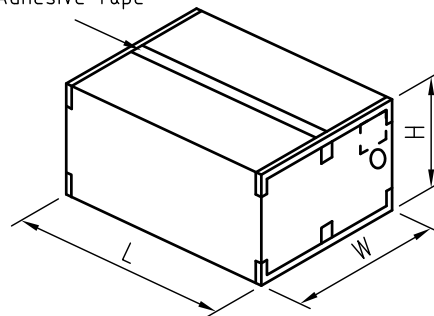

| Circuits | PCS/Bag |
|----------|---------|
| 2        | 1000    |
| 3        | 1000    |
| 4        | 1000    |
| 5        | 1000    |
| 6        | 1000    |
| 7        | 1000    |
| 8        | 1000    |
| 9        | 1000    |
| 10       | 1000    |
| 11       | 1000    |
| 12       | 1000    |
| 13       | 1000    |
| 14       | 1000    |
| 15       | 1000    |

Note注解:

- There shall be no dirt such as deformation phenomenon, Mantissa box fillers must be used  
每箱不可有脏污, 变形现象, 尾数箱必须用填充物
- Confirm whether the inner and outer labels are missing and the content must be consistent with the actual product  
确认内外标签有无漏失, 内容与实物必须一致
- Packing quantity per carton depends on order and delivery quantity  
每箱包装数量依订单及交货数量而定

|          | SPEC.                | Remark   |
|----------|----------------------|--|
| Carton 1 | L460mm×W460mm×H510mm | Use the appropriate carton size according to the actual order quantity 根据实际订单数量使用合适的纸箱尺寸 |
| Carton 2 | L500mm×W500mm×H305mm |  |
| Carton 3 | L580mm×W580mm×H320mm |  |



MARK

1

2

3

4

5

6

7

8

9

TOLERANCE  
X.X ±0.30  
X.XX ±0.20  
X.XXX ±0.10  
Angle ±2°

TITLE:  
DF14 HOUSING  
Packing

UNIT:mm SCALE:N/A

DRAWN: Arwin 2020.03.05

CHECKED:

APPROVED:

SHEET:1/1

PROJECTION

**KONNRA** 东莞市康瑞电子有限公司  
DongGuan Konnra Electronics Co.,Ltd.

PART NO.:H12550\*\*\*\*01A

REV.:A1 DRAWING NO.:1255H01-A-P

RoHS  
COMPLIANT

线夹朝上 (Clamp facing up)

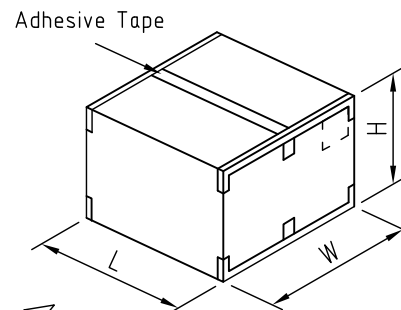
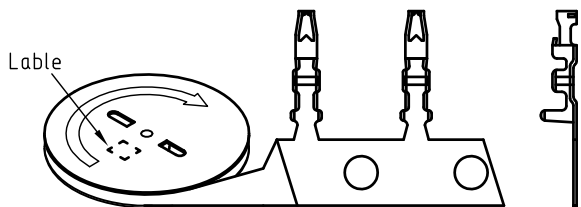

Package way

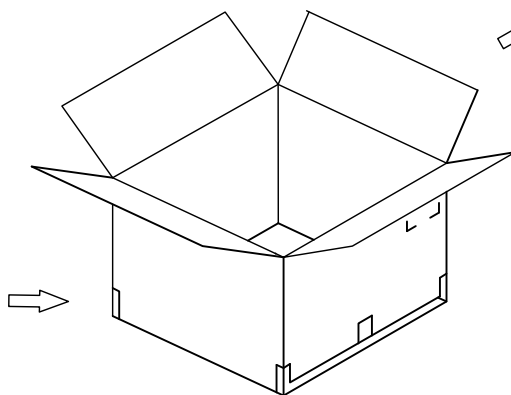
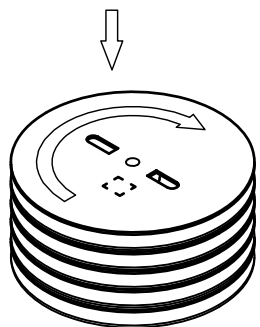

Note注解:

1. There shall be no dirt such as deformation phenomenon, Mantissa box fillers must be used  
每箱不可有脏污，变形现象，尾数箱必须用填充物
2. Confirm whether the inner and outer labels are missing and the content must be consistent with the actual product  
确认内外标签有无漏失，内容与实物必须一致
3. Quantity(数量): 17K PCS/REEL (17K PCS/盘)  
Packing quantity per carton depends on order and delivery quantity  
每箱包装数量依订单及交货数量而定

|          | SPEC.                | Remark   |
|----------|----------------------|--|
| Carton 1 | L460mm×W460mm×H510mm | Use the appropriate carton size according to the actual order quantity 根据实际订单数量使用合适的纸箱尺寸 |
| Carton 2 | L500mm×W500mm×H305mm |  |
| Carton 3 | L580mm×W580mm×H320mm |  |



MARK

REVISION DESCRIPTION

SIGNATURE

DATE

TOLERANCE  
X.X ±0.30  
X.XX ±0.20  
X.XXX ±0.10  
Angle ±2°

TITLE:  
DF14 Terminal  
Packing

UNIT:mm

SCALE:N/A

DRAWN: Arwin 2020.03.05

CHECKED:

APPROVED:

SHEET:1/1

PROJECTION

KONNRA 东莞市康瑞电子有限公司  
DongGuan Konnra Electronics Co.,Ltd.

PART NO.:T1255\*\*0101A

REV.:A1

DRAWING NO.:1255T101-A-P

1

2

3

4

5

6

7

8

9

**RoHS**  
COMPLIANT

02~07 Contacts

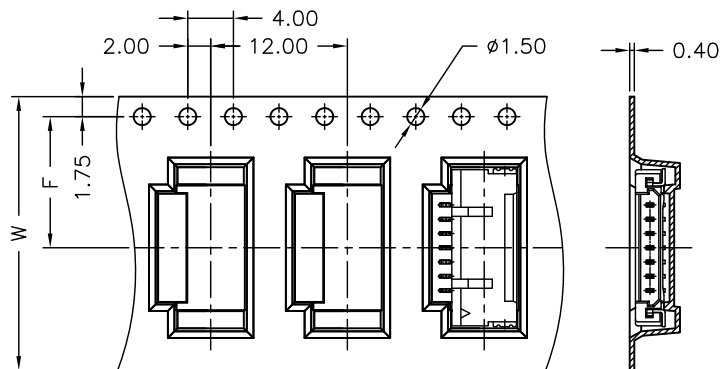

08~30 Contacts

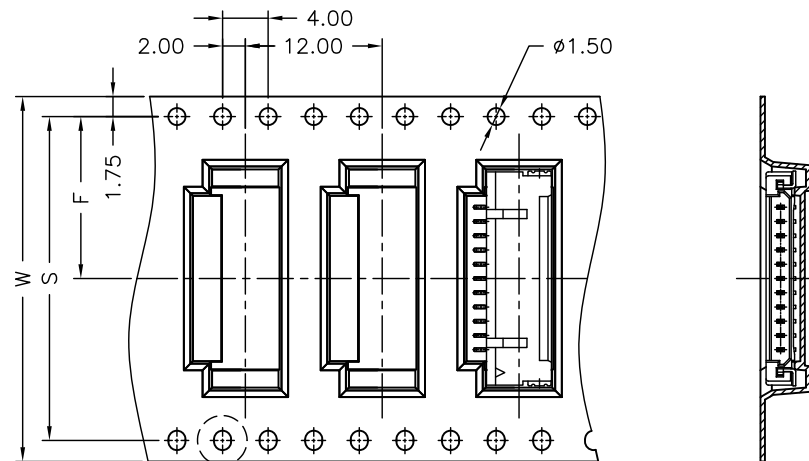

Unreeling direction →

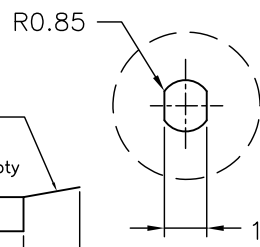
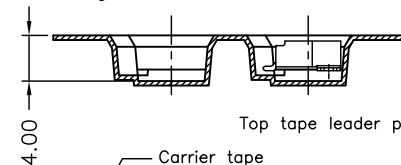

Unreeling direction →

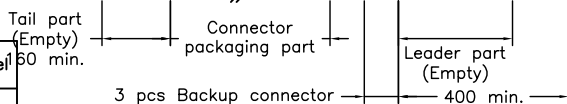
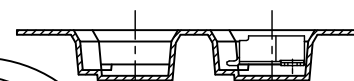

| Number of Contacts | W±0.3 | F±0.1 | S±0.1 | Q'ty/Reel |
|--------------------|-------|-------|-------|-----------|
| 02P                | 16    | 7.50  | /     | 1,000     |
| 03P                | 24    | 7.50  |       | 1,000     |
| 04P                | 24    | 11.50 |       | 1,000     |
| 05P                | 24    | 11.50 |       | 1,000     |
| 06P                | 24    | 11.50 |       | 1,000     |
| 07P                | 24    | 11.50 |       | 1,000     |
| 08P                | 32    | 14.20 |       | 28.40     |
| 09P                | 32    | 14.20 | 28.40 | 1,000     |
| 10P                | 32    | 14.20 | 28.40 | 1,000     |
| 11P                | 32    | 14.20 | 28.40 | 1,000     |
| 12P                | 32    | 14.20 | 28.40 | 1,000     |
| 13P                | 44    | 20.20 | 40.40 | 1,000     |
| 14P                | 44    | 20.20 | 40.40 | 1,000     |
| 15P                | 44    | 20.20 | 40.40 | 1,000     |
| 20P                | 44    | 20.20 | 40.40 | 1,000     |
| 21P                | 44    | 20.20 | 40.40 | 1,000     |
| 25P                | 56    | 26.20 | 52.40 | 1,000     |
| 30P                | 56    | 26.20 | 52.40 | 1,000     |

NOTE:

Material: Transparent  
Anti-static Polystyrene.

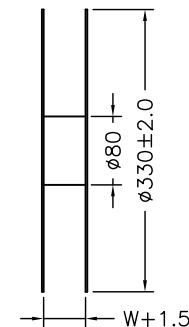
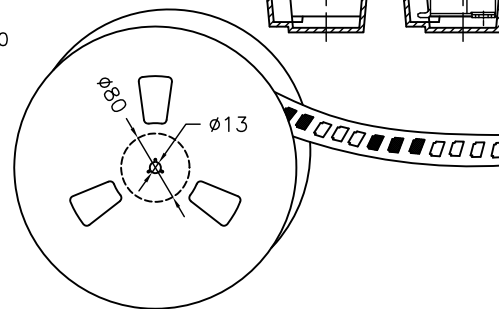

New Specifications

Shen 2020.06.18

MARK

REVISION DESCRIPTION

SIGNATURE

DATE

TOLERANCE  
X.X ±0.30  
X.XX ±0.20  
X.XXX ±0.10  
Angle ±2°

TITLE:  
DF14 SMT 90°Wafer  
Series packing

UNIT:mm

SCALE:1/1

DRAWN: Shen 2020.6.18

CHECKED:

APPROVED:

SHEET:1/1

PROJECTION

**KONNRA** 东莞市康瑞电子有限公司  
DongGuan Konnra Electronics Co.,Ltd.

PART NO.: C1255RS\*\*\*\*M0101RA

REV.:A1

DRAWING NO. 1255WRS101-A-P