

RoHS
COMPLIANT

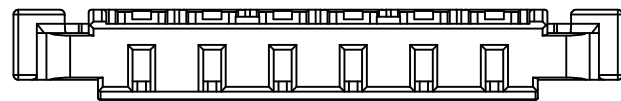
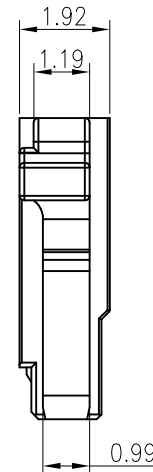
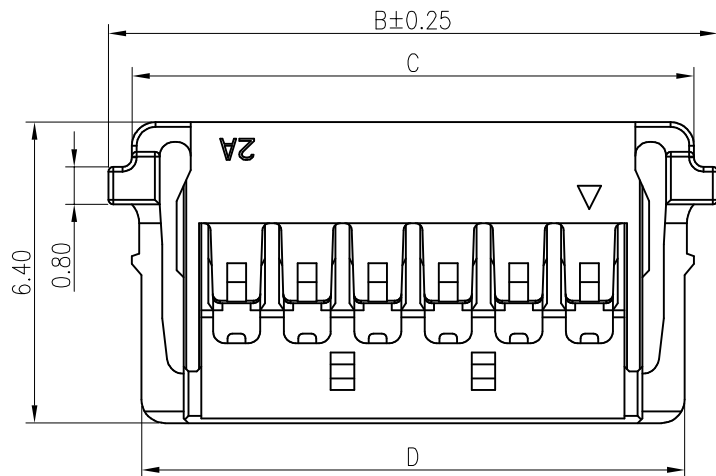
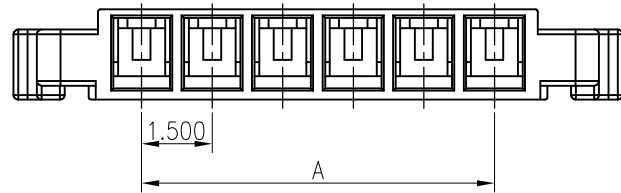

SPECIFICATIONS

1. Current rating: 3A AC, DC
2. Voltage rating: 150V AC,DC
3. Temperature range: -25°C ~ +85°C
4. Insulation resistance: 1000MΩ/ min.
5. Withstanding voltage: 500V AC/ minute.
6. Contact resistance: 20mΩ/ max.

Material:PA66 UL 94V-0
Suitable KR1509 series terminal
Mate with KR1509 series wafer

Ordering Code:

H15090 *** ** 01A

No.of Circuits
102:02,112:12

Insulator Material
02:PA66 Black V0

Circuits	Dimensions			
	A	B	C	D
2	3.00	6.95	5.95	5.55
3	4.50	8.45	7.45	7.05
4	6.00	9.95	8.95	8.55
5	7.50	11.45	10.45	10.05
6	9.00	12.95	11.95	11.55
7	10.50	14.45	13.45	13.05
8	12.00	15.95	14.95	14.55
9	13.50	17.45	16.45	16.05
10	15.00	18.95	17.95	17.55
11	16.50	20.45	19.45	19.05
12	18.00	21.95	20.95	20.55

△4			
△3			
△2			

TOLERANCE
X.X ±0.30
X.XX ±0.20
X.XXX ±0.10
Angle ±2°

TITLE:
1.5 Side Buckel
Housing

DRAWN: Arvin 2020.03.05

CHECKED:

APPROVED:

KONNRA 东莞市康瑞电子有限公司
DongGuan Konnra Electronics Co., Ltd.

PART NO. : H15090***0201A

MARK	REVISION DESCRIPTION	SIGNATURE	DATE	UNIT: mm	SCALE: N/A	SHEET: 1/1	PROJECTION	REV. : A1	DRAWING NO. : 1509H101-A-S
------	----------------------	-----------	------	----------	------------	------------	------------	-----------	----------------------------

1 2 3 4 5 6 7 8 9

RoHS
COMPLIANT

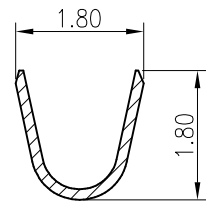
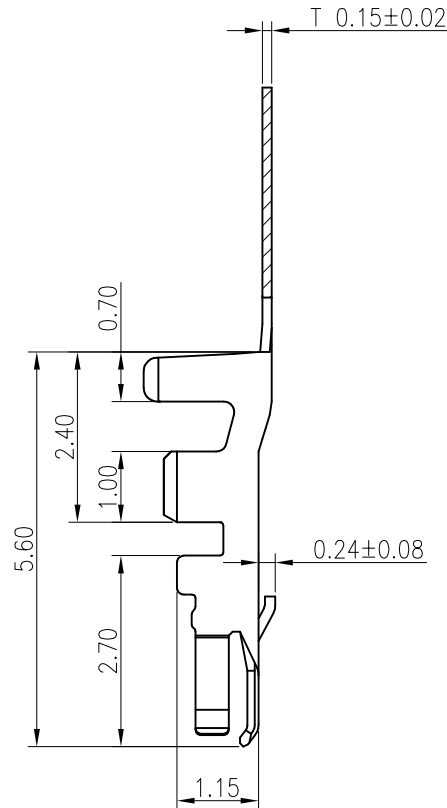
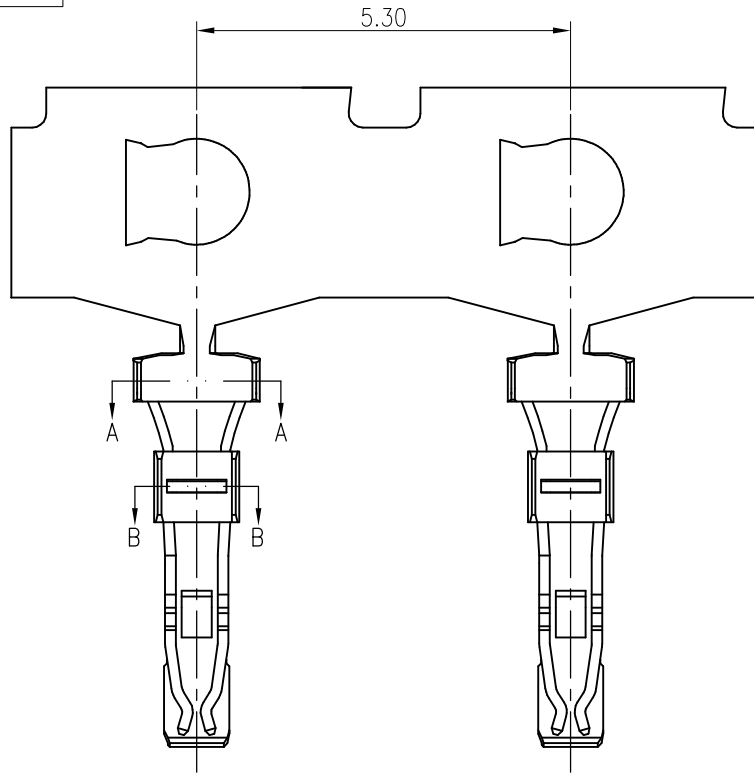

SECTION A-A

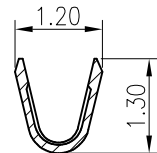

SECTION B-B

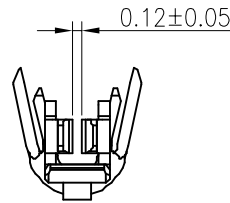

SPECIFICATIONS

1. Current rating: 3A AC, DC
2. Voltage rating: 150V AC,DC
3. Temperature range: -25°C ~ +85°C
4. Insulation resistance: 1000MΩ/ min.
5. Withstanding voltage: 500V AC/ minute.
6. Contact resistance: 20mΩ/ max.

Applicable Wires:

AWG#24~#28

Insulation O.D. : 1.10mm MAX

Material: Phosphor Bronze

Plating: Gold flash over Nickel

Suitable 1509 series crimp housing

Q'ty/reel: 10,000 PCS

F	△4				TOLERANCE X.X ±0.30 X.XX ±0.20 X.XXX ±0.10 Angle ±2°	TITLE: 1.5 Side Buckel Terminal	DRAWN: Arvin 2020.03.05		KONNRA 东莞市康瑞电子有限公司		
	△3						CHECKED:		DongGuan Konnra Electronics Co., Ltd.		
	△2						APPROVED:		PART NO. : T15090PG0101A		
	MARK	REVISION DESCRIPTION	SIGNATURE	DATE			UNIT: mm	SCALE: N/A	SHEET: 1/1	PROJECTION	REV. : A1
	1	2	3	4	5	6	7	8	9		

RoHS
COMPLIANT

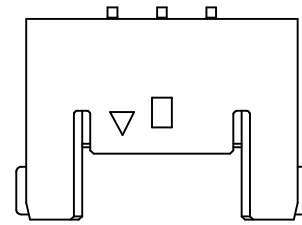
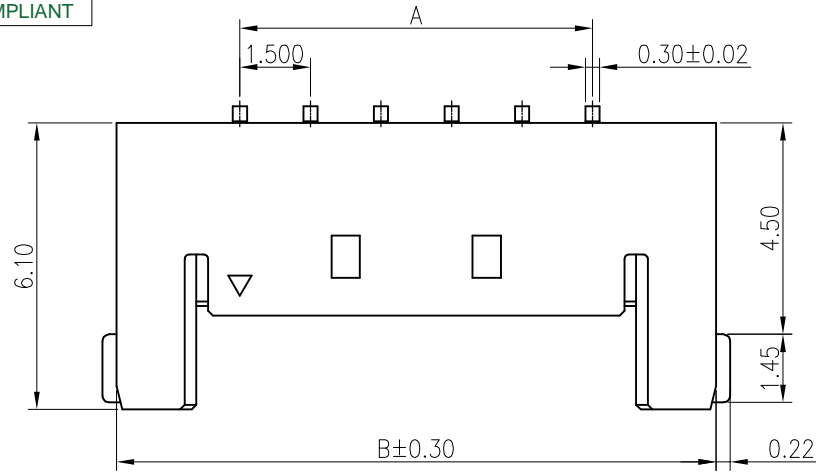

2P-4P Single Hole
Scale 1:0.7

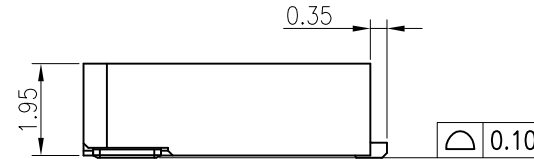

SPECIFICATIONS

1. Current rating: 3A AC, DC
2. Voltage rating: 150V AC,DC
3. Temperature range: -25°C ~ +85°C
4. Insulation resistance: 1000MΩ/ min.
5. Withstanding voltage: 500V AC/ minute.
6. Contact resistance: 20mΩ/ max.

Material:

Insulator: PA4T UL 94V-0
Contact: Brass/Gold flash over Nickel
Solder tabs: Brass/Tin plated over Nickel
Mate with KR1509 series Housing

Ordering Code:

C1509RS *** ** G0101RA

No.of Circuits

102:02,112:12

Insulator Material

42:PA4T Black

Plating

G01:Gold flash

Circuits	Dimensions	
	A	B
2	1.50	6.75
3	3.00	8.25
4	4.50	9.95
5	6.00	11.25
6	7.50	12.75
7	9.00	14.25
8	10.50	15.75
9	12.00	17.25
10	13.50	18.75
11	15.00	20.25
12	16.50	21.75

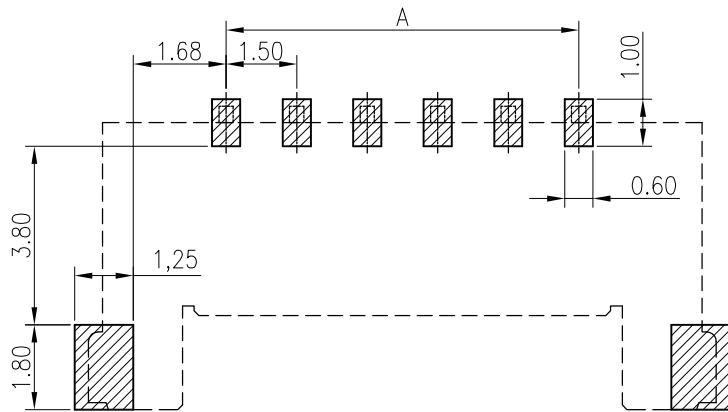

Recommended P.C.B. Layout
Total tolerance:±0.05mm

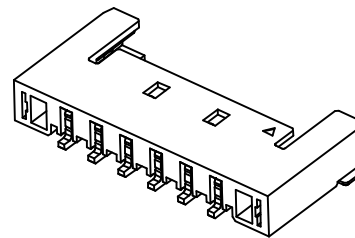

MARK

1

2

3

4

5

6

7

8

9

TOLERANCE

X. X ±0.30

X. XX ±0.20

X. XXX ±0.10

Angle ±2°

TITLE:
1.5 Side BuckelSM^T
90° Wafer

UNIT: mm

SCALE: N/A

DRAWN: Arvin 2020.03.05

CHECKED:

APPROVED:

SHEET: 1/1

PROJECTION

KONNRA 东莞市康瑞电子有限公司

DongGuan Konnra Electronics Co., Ltd.

PART NO. : C1509RS***42G0101RA

REV. : A1

DRAWING NO. : 1509WRS101-A-S